

The MAX2681 SiGe Downconverter Mixer Tuned for GPS Front Ends

This application note presents the component values and measured performance for the MAX2681 mixer IC when tuned for GPS operation at 1575MHz. The evaluation kit schematic is provided. Conversion gain is 10.5dB, and the input third order intercept is -0.8dBm.

Additional Information: [Wireless Product Line Page](#)

[Quick View Data Sheet for the MAX2680/MAX2681/MAX2682](#)

[Applications Technical Support](#)

The MAX2681 is a miniature, low-cost, low-noise downconverter mixer designed for low-voltage, low-current operation, and is ideal for portable communications equipment. The MAX2681 can be used with input radio frequencies (RFs) between 400MHz and 2500MHz, to downconvert to intermediate frequencies (IF) between 10MHz to 500MHz. The input RF for a global positioning system (GPS) receiver is 1575MHz. Assuming a 70MHz IF, and high-side local oscillator (LO) injection ($f_{LO} = 1645\text{MHz}$), the MAX2681 achieves +10.5dB of gain, has a noise figure of 9.6dB, an input third-order intercept point (IIP3) of -0.8dBm and draws 8.8mA of supply current from a +3.0V supply. See Figure 1 for component values and the schematic.

For application of the MAX2681 at 900MHz, 1950MHz or 2450MHz, or for further device information, consult the MAX2680/MAX2681/MAX2682 data sheet. For higher input IP3 performance, refer to the application note "[MAX2682 SiGe Downconverter Mixer Tuned for GPS Applications](#)".

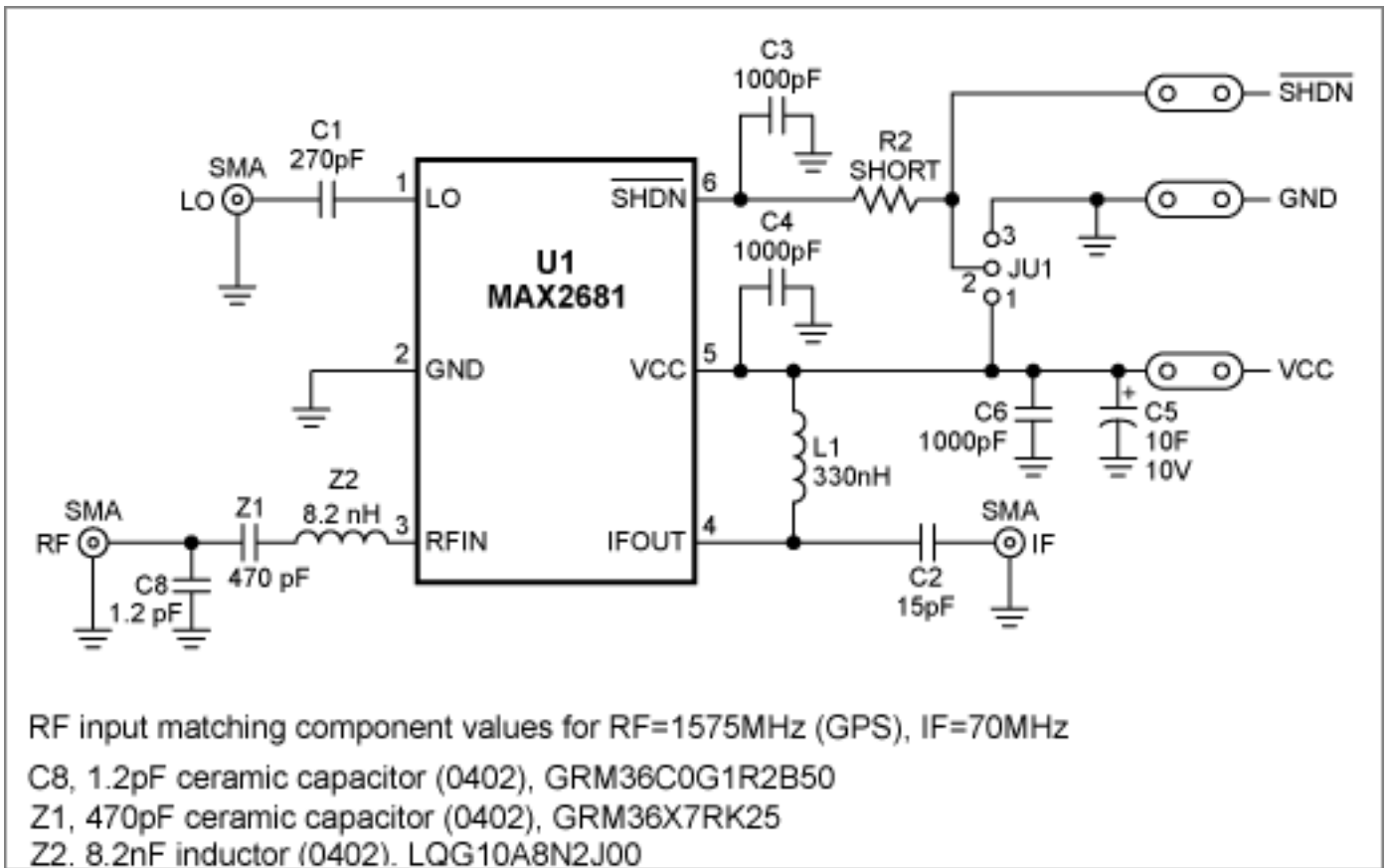

Figure 1. The MAX2681 EV kit schematic

Table 1. The MAX2681 GPS Performance

$V_{CC} = +3.0V$, $f_{RF1} = 1575MHz$, $f_{RF2} = 1576MHz$, $f_{LO} = 1645MHz$, $P_{LO} = -5dBm$, $f_{IF} = 70MHz$

Parameter	Measure Performance
Conversion Gain	+10.5dB
Noise Figure	9.6dB
Input Third-Order Intercept Point	-0.8dBm
RF Input Return Loss	-19.3dB
Supply Current	8.8mA

NOTE: PCB losses are not taken into account.

More Information

MAX2680: [QuickView](#) -- [Full \(PDF\) Data Sheet](#) -- [Free Samples](#)

MAX2681: [QuickView](#) -- [Full \(PDF\) Data Sheet](#) -- [Free Samples](#)

MAX2682: [QuickView](#) -- [Full \(PDF\) Data Sheet](#) -- [Free Samples](#)